

A-Y3-3-UHF UHF YAGI ANTENNA

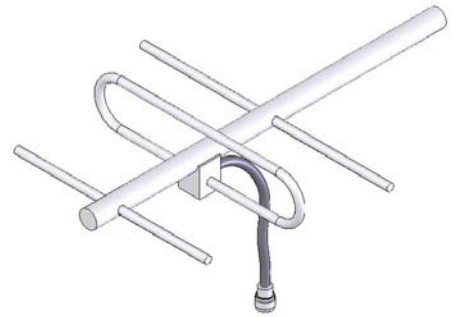

A-Y3-3-UHF UHF yagi antennas have been manufactured to withstand the rigours of the WA desert/marine environments and have been used for many years by western Australian government, departments and mining companies. The antennas are either 6060T5 grade (Grade A corrosion resistant) Aluminium Alloy completed in a robust powder coat or 316 Grade Stainless steel All joins are TIG or MIG welded and the antennas when installed in accordance with the instructions supplied will have an extraordinary long working life. Optional mounting hardware. Cable tails terminated with a N female connector.

Specification

Frequency:	400 – 520 MHz (457 MHz)
VSWR at FC:	Less than 1.5:1
Bandwidth at VSWR1.5:1	4%
Nominal Impedance:	50 Ohm
Termination:	Cable tail to N type female (tail 600L)
Power Rating:	200 Watts
Forward Gain:	6 dBd
Approx. Weight:	0.4 Kg Aluminum & 0.8 Kg stainless steel
Wind Loading at 160Kmh:	4.7 Kg
Length at 457 MHz:	495 mm
Boom Diameter:	25mm
Front to Back Ratio:	20dB
Phasing Harness Availability:	2, 3 & 4 way
-3dBd Beamwidth H Plane:	78 Deg
-3dBd Beamwidth E Plane:	57 Deg

Mechanical Layout:

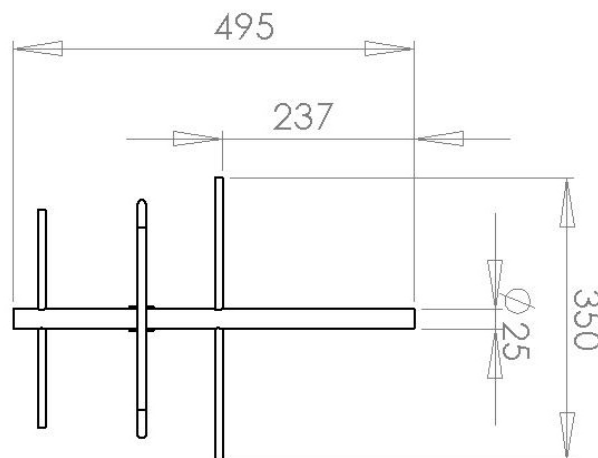

Typical Test Result

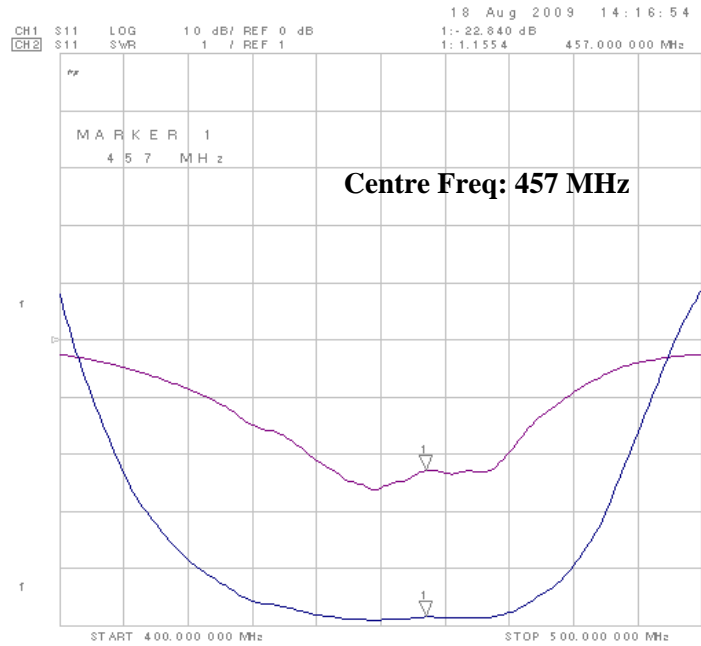

Installation Guide

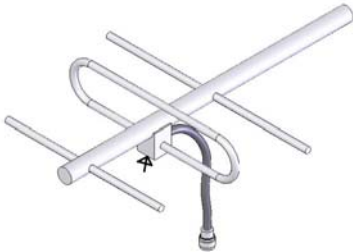

- Horizontal Polarization
- Dipole Mounting Block Facing Down
- Do not change length of cable tail. Return to factory to fix any damage.
- Seal the coaxial connectors by using self-vulcanizing tape

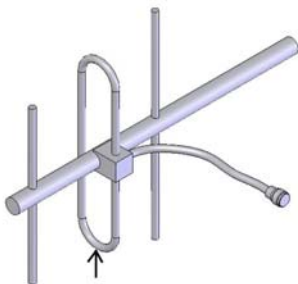

- Vertical Polarization
- Keep the drain holes face down
- Do not change length of cable tail. Return to factory to fix any damage.
- Seal the coaxial connectors by using self-vulcanizing tape
- Seal the coaxial connectors by using self-vulcanizing tape